

SCUPPER DRAIN CAST IRON BODY WITH OBLIQUE ALUMINIUM GRATE  
MODEL NO: **R2467-90**

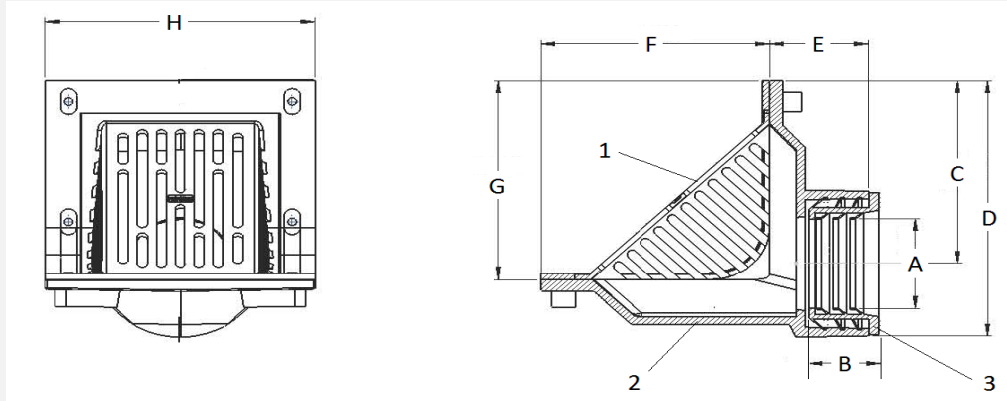

✓ **PRODUCT DESCRIPTION:** Epoxy Coated Cast Iron Body Scupper Drains with sizes 6" x 7" [162mm x 191mm] or 8" x 12" [213mm x 318mm]. Reversible back or bottom outlet, oblique aluminum grate with 90° combination frame and membrane flashing clamp.

✓ **CRITICAL TO QUALITY (CTQ) DIMENSION :**

DIMENSION	DESCRIPTION	DIMENSION IN INCHES {mm}	
		3	4
A	PIPE SIZE	3 (73)	4 (103)
B	GASKET HEIGHT	1-15/16 (50)	1-3/4 (45)
C	PIPE HUB CENTRE TO TOP	5-7/8 (149)	5-3/8 (137)
D	C.I BODY HEIGHT	8-3/16 (208)	8-3/16 (208)
E	PIPE HUB DISTANCE	2-3/4 (70)	2-3/4 (70)
F	OBLIQUE GRATE LENGTH	6-3/8 (162)	6-3/8 (162)
G	OBLIQUE GRATE HEIGHT	6-3/8 (162)	6-3/8 (162)
H	OBLIQUE GRATE WIDTH	7-1/2 (191)	7-1/2 (191)
GRATE OPEN AREA Sq. In. (cm <sup>2</sup> )		31 (200)	
OUTLET TYPE		INSIDE GASKET	

✓ **LIST OF COMPONENTS :**

COMPONENT	DESCRIPTION
1	OBLIQUE ALUMINIUM GRATE
2	CAST IRON BODY
3	NEO LOC GASKET
4	GI HT FLANGE HEX HEAD BOLT 8 MM X 20MM